

**ergocar basic/ergocar PC – Equipment Cart
Technical Specifications**

**ergocar basic
Dimensions**

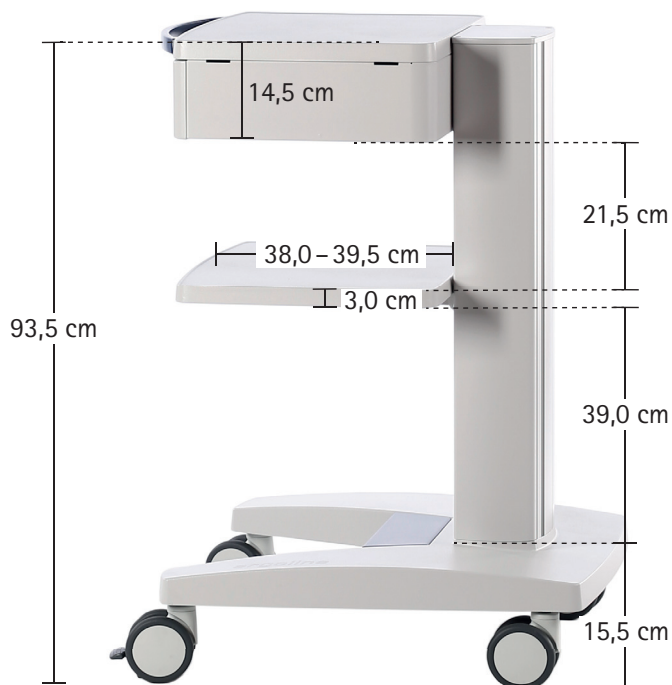

Dimensions and weight – ergocar basic

Length: 60 cm
Width: 60 cm
Height: 90 cm
Weight: approx. 45 kg

**Dimensions and weight – ergocar basic
with packaging (without pallet)**

Length: 68 cm
Width: 70 cm
Height: 100 cm
Weight: approx. 67 kg



**ergocar basic/ergocar PC – Equipment Cart
Technical Specifications**

**ergocar PC
Dimensions**

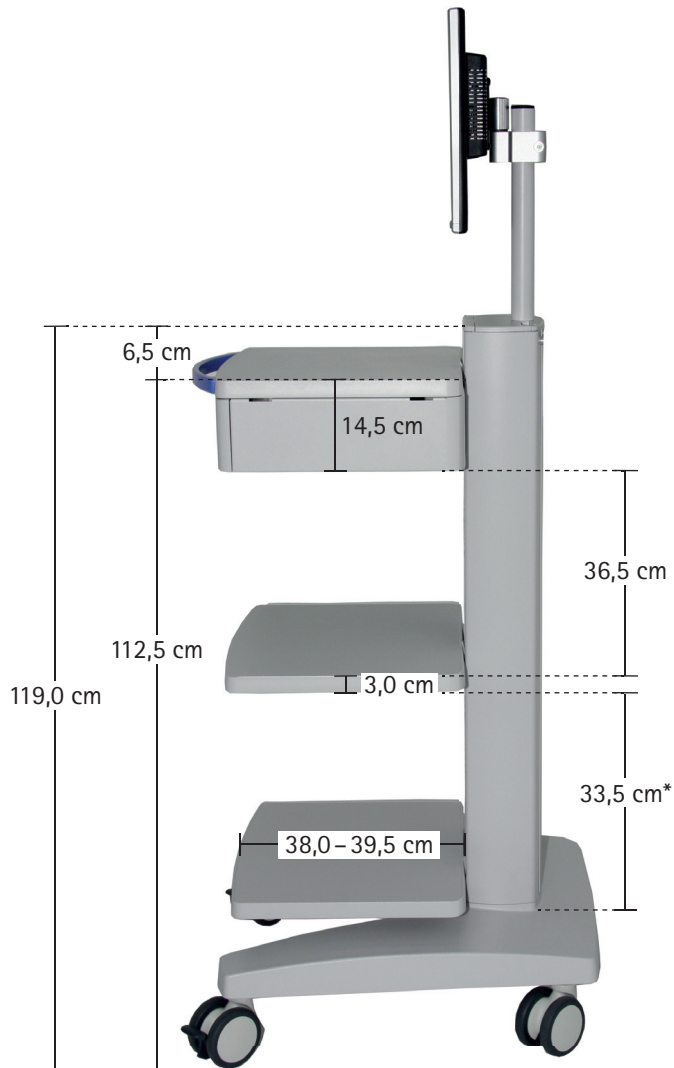

Dimensions and weight – ergocar PC

Length: 60 cm
Width: 60 cm
Height: 119 cm
Weight: approx. 51 kg

**Dimensions and weight – ergocar PC
with packaging (without pallet)**

Length: 68 cm
Width: 70 cm
Height: 124 cm
Weight: approx. 81 kg

* Due to design constraints, the clearance below the shelf is reduced by the dimensions indicated in the illustration below.

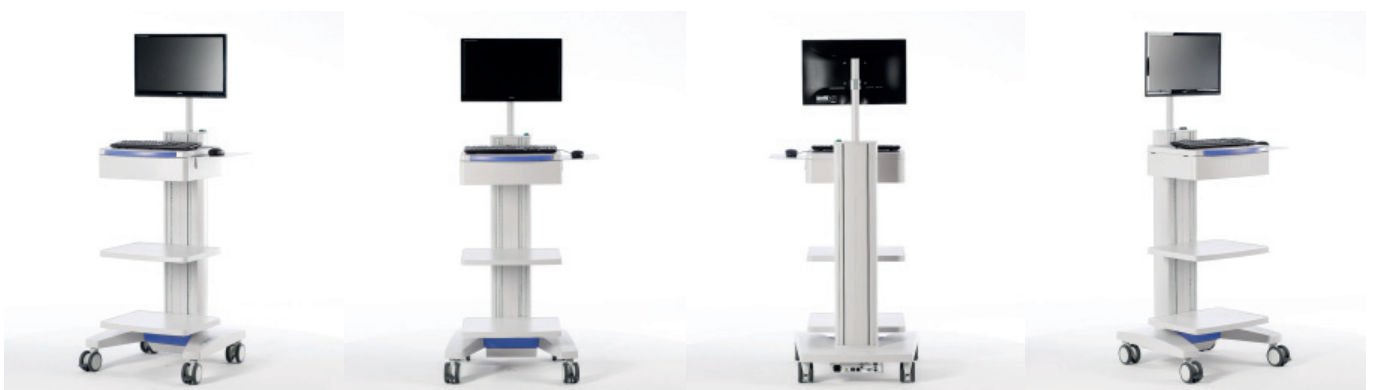
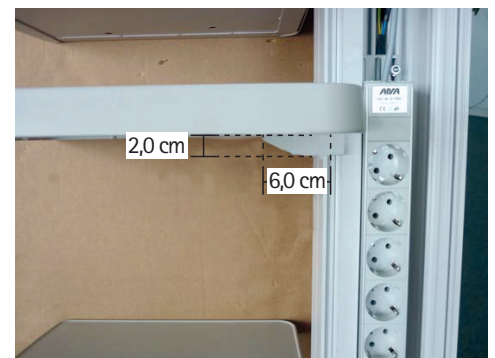

ergocar basic/ergocar PC – Equipment Cart Technical Specifications

Equipment cart	ergocar basic/ergocar PC	
Load capacity	basic frame, overall: 80 kg	
	shelf	20 kg (surface load)
	drawer:	4 kg
Grid for fixation of shelves	30 mm	
Dimensions		
Width	600 mm	
Depth	600 mm	
Height	900 mm (ergocar basic) 1190 mm (ergocar PC without monitor)	
Shelf storage space (W x D)	500 x 400 mm	
Monitor holders		
Mounting	VESA 75 x 75 / 100 x 100 / 200 x 100	
Monitor weight	12 kg max.	
Monitor size dual monitor holder	up to 19 "	> 19 " (with monitor arm extension).
Isolating transformer		
Voltage	versions for 110 V / 230 V	
Power	800 VA / 1200 VA / 1400 VA	
Safety	in compliance with IEC 60601-1	
Expansion options / accessories		
Numerous expansion options, accessories etc. are available	<i>on request</i>	